

# IDQ 12 (DUAL BANDPASS)

4.14 CUFT:

TUNED AT 75 HRZ:

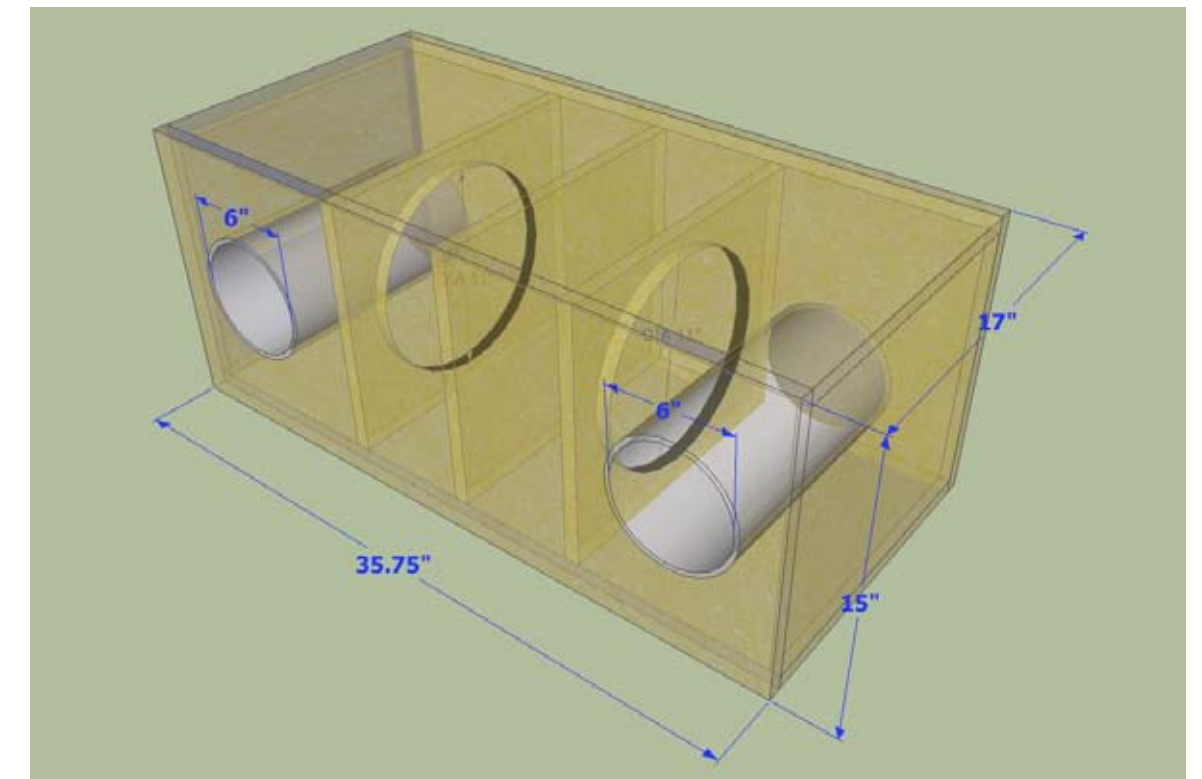
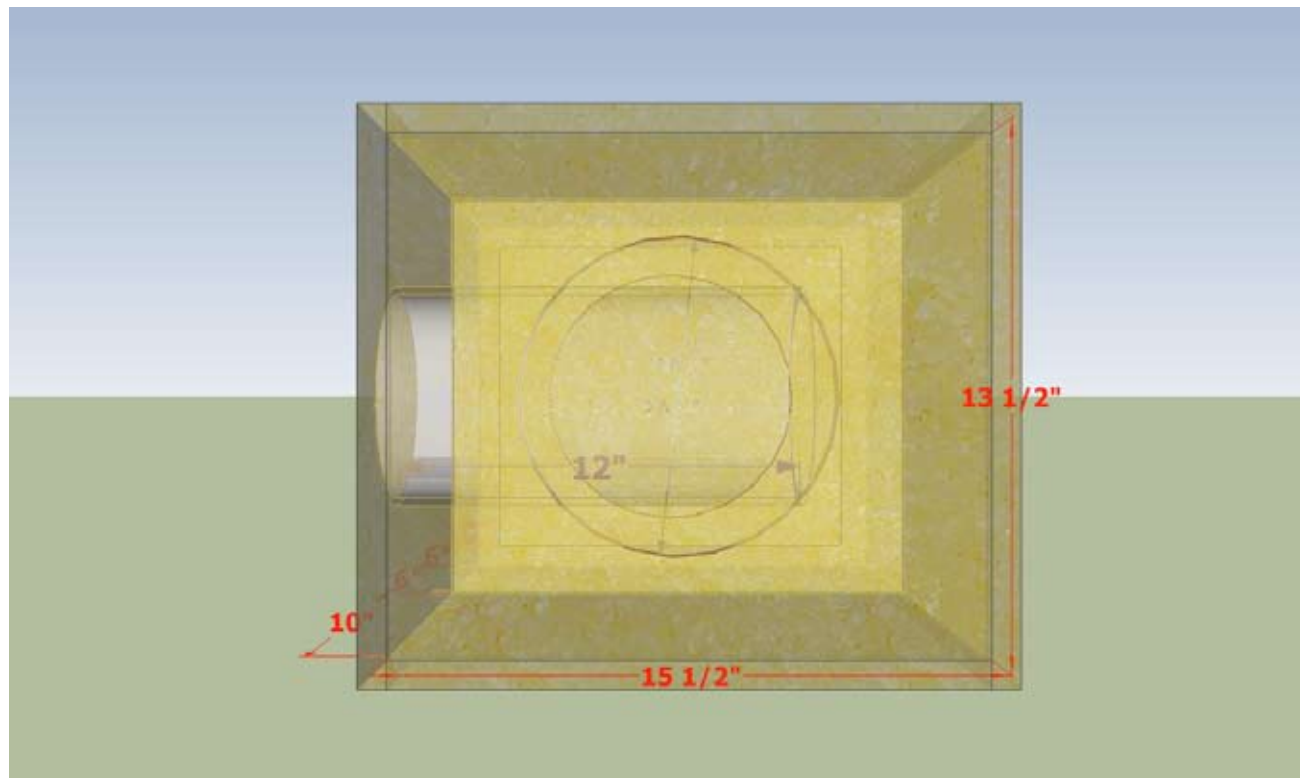
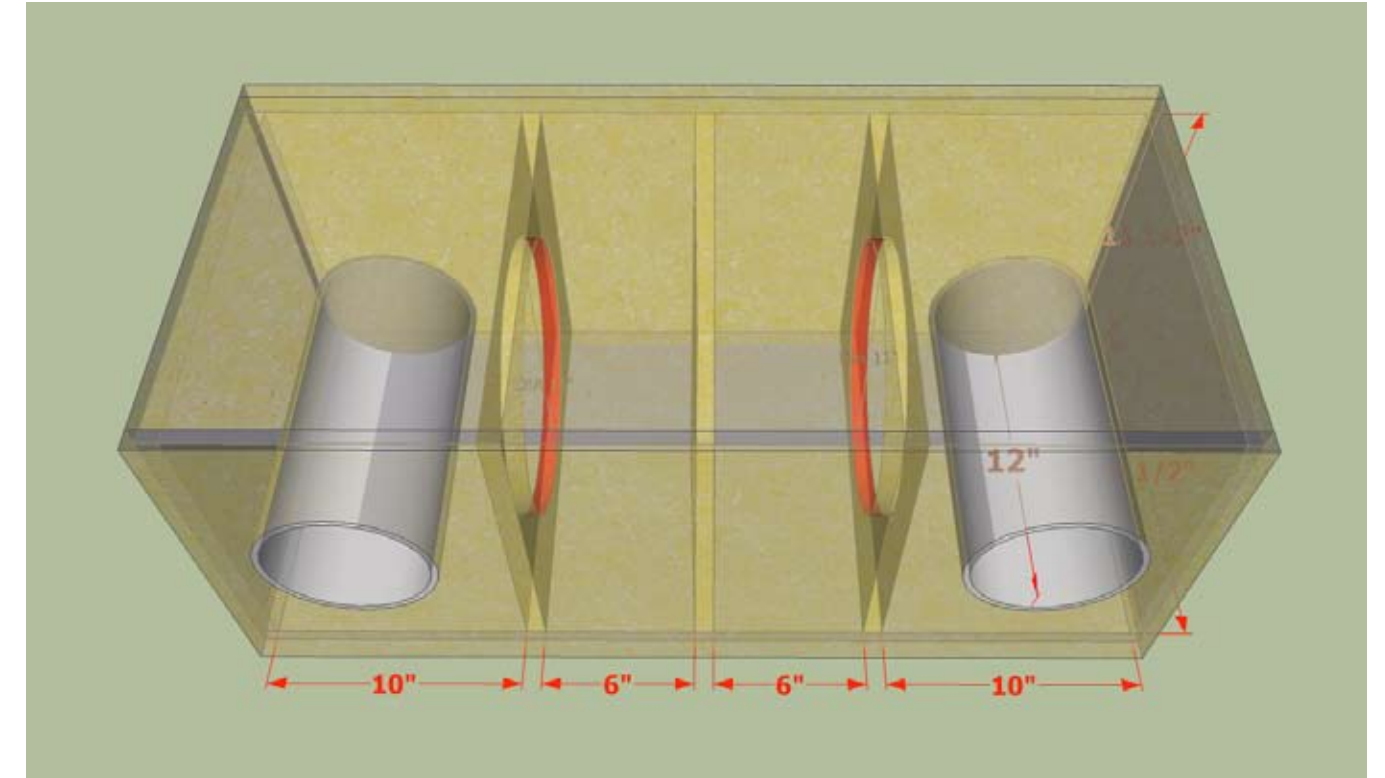
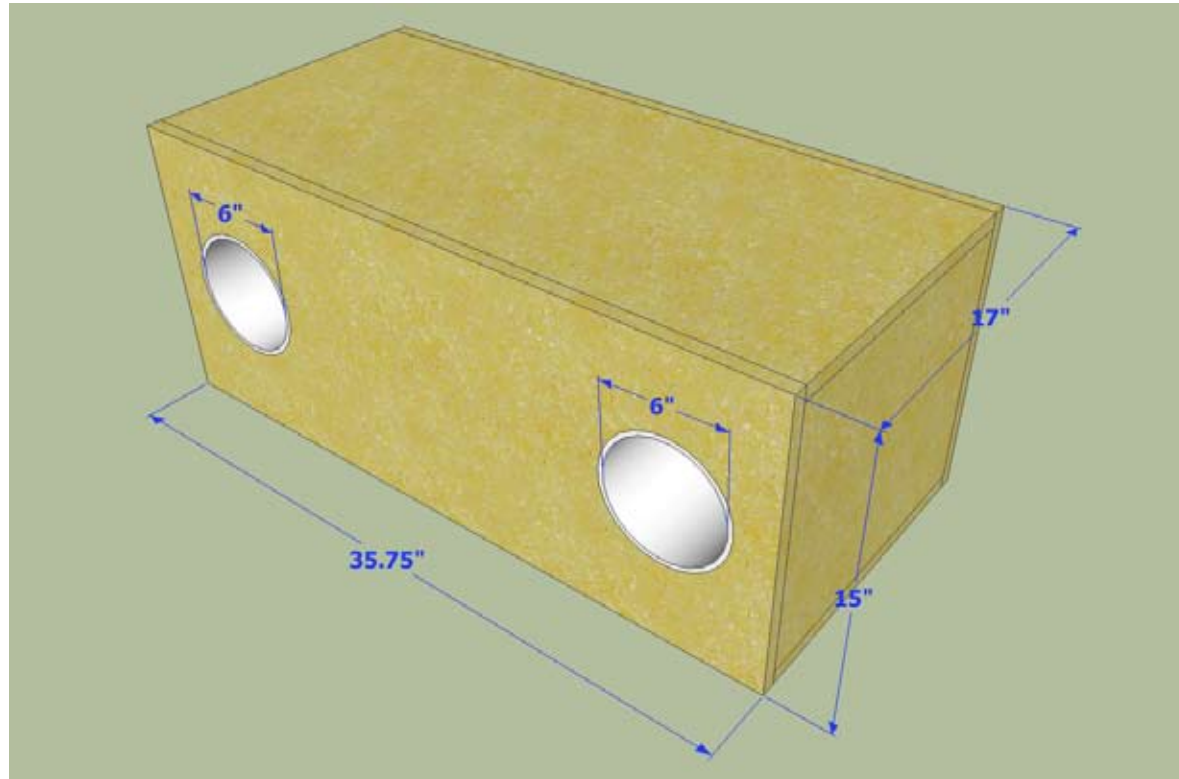

# INCAR SPL AND CUT SHEET:



BASIC CUT SHEET YOUR DESIGN MAY VARY FOR YOUR CAR OR TRUCK...  
LAYOUT: YOU WILL NEED TO CUT THESE BOARDS OUT OF 3/4" MDF

- 2- 35.75" X 15.5" TOP/BOTTOM PANELS
- 2- 35.75" X 15" FRONT /REAR PANELS
- 5- 15.5" X 13.5" SIDE /INSIDE PANELS

PORT:  
2- 6" ROUND PVC PORTS BY 12" LONG

BOTH SEALED CHAMBERS IN THE MIDDLE NEED TO STUFF WITH 1.5 POUNDS OF FIBERGLASS FILL @ 100%

DESIGNED BY MATT BORGARDT

# ENCLOSURE FACTS : BAND-PASS

## Facts:

The Term **Band-pass** is an adjective that refers to some form of filtering, this was first described in electrical components and then later used to describe the filtering used to control the enclosure output. When using a **Band-pass** design there are limits placed on the enclosure and its performance, in some cases these limits come from poor design or limited space. In most cases the design will yield larger enclosures than its ported or sealed cousins that can yield the same or better

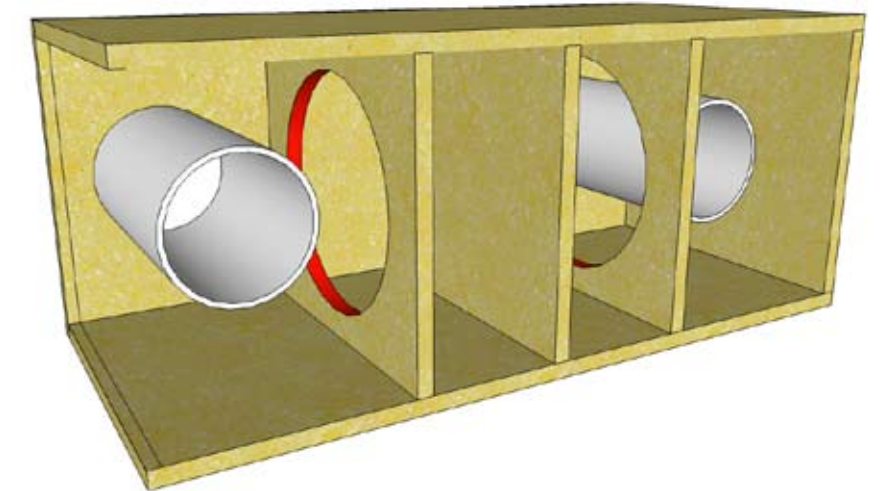

performance when placed in the right environment. If obstructions such as a rear deck or well insulated rear seats are in the way the **Band-pass** design will be one of your best bets. Using a **Band-pass** design you are able to direct the output into the vehicle cabin via holes in the rear deck allowing the enclosure to produce a flat response curve and life-like sound. In the past many manufactures designed "Poor" or "Off the shelf" enclosures that have a "Thick" or "One note Wonder" type of sound, this left many people to believe that a **Band-pass** design was only for teenaged bass styles. Like all other enclosures the **Band-pass** can be a very effective design if used correctly yielding efficiency and a good pass-band.